

Vertical balers

B-series



Baler B30

Extra wide and easy to fill

B30 is a wide baler. It is very easy to fill with larger boxes and other bulky waste.

Simple operation

A small light on the front flashes when a bale is ready. This reduces the risk of overfilling the chamber. The bale is ejected automatically by pressing two buttons simultaneously.

Highlights

- Wide opening and large chamber
- Retainers prevent compacted material from expanding
- Strap roles in the front means no going behind the machine
- Bale straps are easily cut with the mounted knife
- Full chamber indicator

Optional Extras



Gain remote control of your baler with our intelligent fleet monitoring system, BRA-IN.

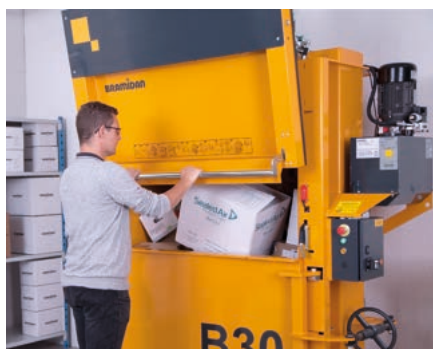

A vertical door gives you unobstructed loading from both sides.



Balers are available in other RAL colours which you may choose.

Product details

Baler B30



Whisper

30 dB



Refrigerator

50 dB



B30 baler

62-64 dB



Other balers

75 dB

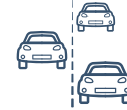

Cars on highway

100 dB



Turbojet engine

160 dB

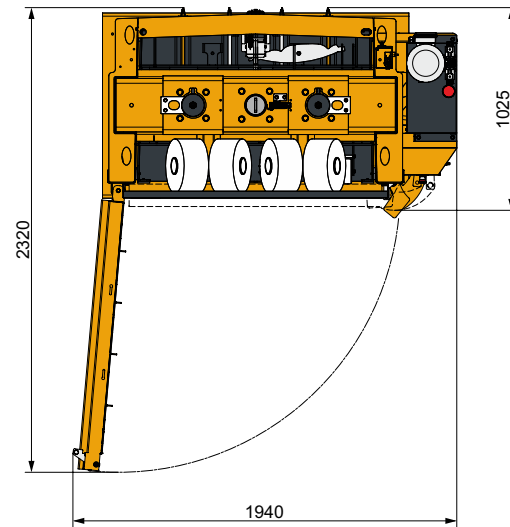
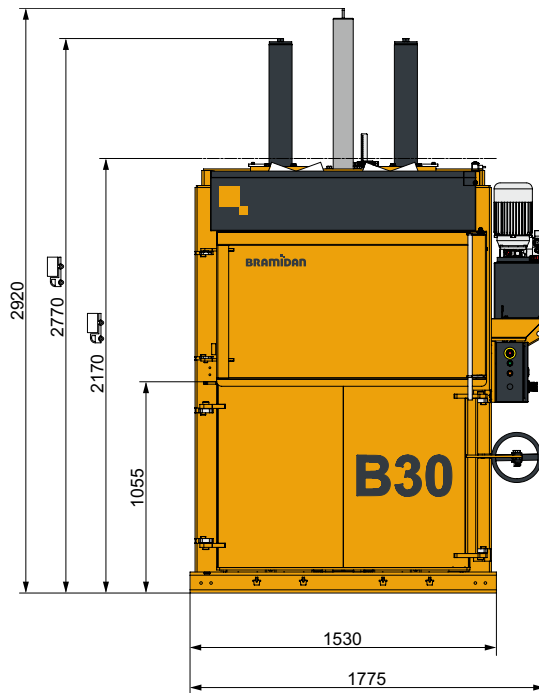

Technical specifications

Bale size WxDxH (mm)	1200 x 800 x 950
Feed opening WxH (mm)	1200 x 560
Power supply	3x400V 50Hz 16A
Motor (kW)	4.0
Cycle time avg. (sec)	34 / 51
Dimensions WxDxH (mm)	1775 x 1025 x 2920
Machine weight (kg)	1560
Stroke (mm)	750
Number of ties	4
Type of tying	Twine / Steel wire
Full bale light	Yes
Bale eject	Automatic



Bale weight

Cardboard (kg) 280-350
Plastic foil (kg) 350-450



Press force

30 t



Noise level

62-64 dB



Waste types

Cardboard, plastic foil, paper

BRAMIDAN
www.bramidan.com

Bramidan A/S
Industrivej 69
6740 Bramming
Denmark
Tel: +45 7517 3266
bramidan@bramidan.dk