

WEIGHT : 6398,27 kg	
FOR GENERAL NOTES, SEE LATEST EDITION OF - BRAMIDAN TECHNICAL NOTES -	
Bramidan A/S Industrivej 69 DK - 6740 Bramming Denmark Tel. +45 761 73266 www.bramidan.com	<p>CHANNEL BALER, HC40</p> <p>LAYOUT FOR PROJECT PRB910236</p> <p>DRAWING NO. HCF11002</p>
0	1 / 2

EXTRA HOPPER SIDES FOR CONVEYOR

WIRE MAGAZINE FOR UPPER WIRE

HYDRAULIC PUMP UNIT

ELECTRICAL CONTROL AND USER PANEL

BRAMIDAN CHANNEL BALER MODEL HC40

STANDARD HAND-FEEDING HOPPER

WIRE MAGAZINE FOR LOWER WIRE

INSPECTION DOOR
AT THIS LOCATION.
(DOOR NOT SHOWN)

BALE SLIDE

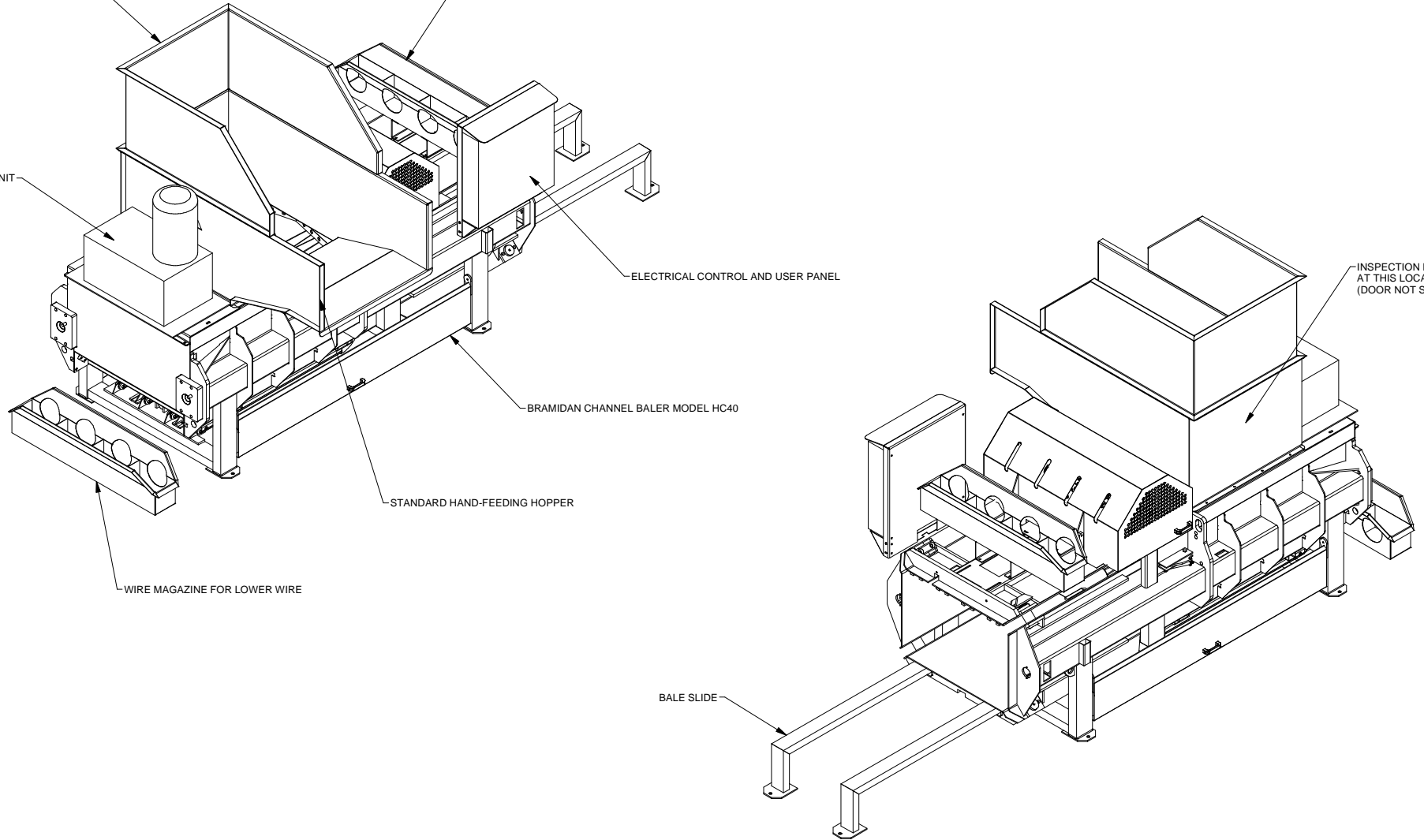

WEIGHT : 6388,27 kg			
FOR GENERAL NOTES, SEE LATEST EDITION OF - BRAMIDAN TECHNICAL NOTES -			
Bramidan A/S Industrivej 69 DK - 6740 Bramming Denmark Tel. +45 76173266 www.bramidan.com		BRAMIDAN CHANNEL BALER, HC40 LAYOUT FOR PROJECT PRB910236	
REV	DATE	BY	APP
0	09-03-2011	ECC	
DRAWING NO. HCF11002			2 / 2